



TJM Innovations - Magnacraft

5519 W. Woolworth Ave.

Milwaukee, WI 53218

Phone: (414) 206-2944

E-Mail: orders@magnacraft.net

Website: magnacraft.net

530-S Shuttle Base

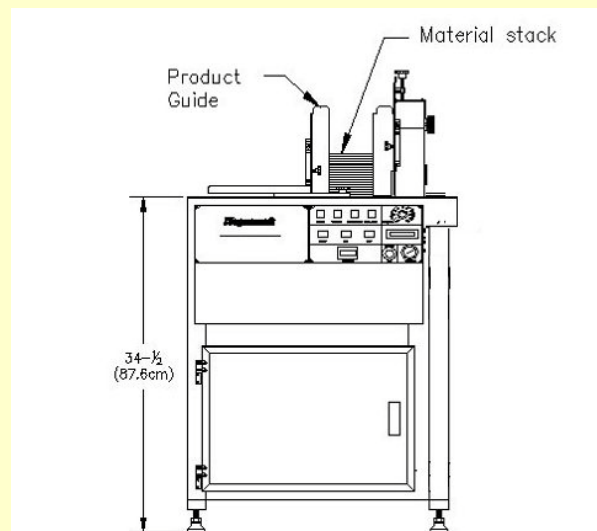
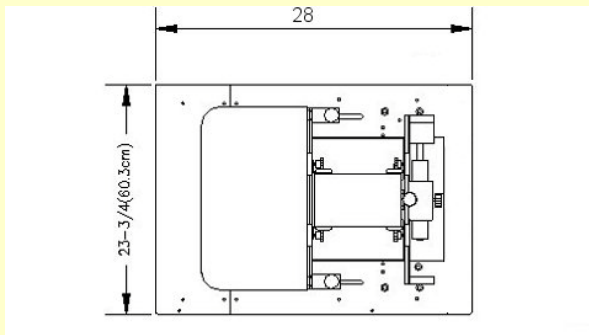

Specifications

Machine

Dimensions: 28" L x 30" W x 32½ - 34½" H

Weight: 380 Pounds

Roller Cabinet

Vacuum Shuttle

Electrical

Power Requirements: 230 VAC, 60 Hz, 1 Ph, 12A

Motor: 1/4 HP, DC Drive

Vacuum Pump: 3/4 HP Oilless Rotary Vane

Product

Minimum Size: 3" x 5" x 20#

Maximum Size: 13.0" x 13.0" x 0.375"

Throughput: 30,000 pieces per hour (product dependent)

Product Spacing: Variable

Application

Mail Table Feeder

Roll up to an inline addressing system