



TJM Innovations - Magnacraft

5519 W. Woolworth Ave.

Milwaukee, WI 53218

Phone: (414) 206-2944

E-Mail: orders@magnacraft.net

Website: magnacraft.net

MagShuttle : Shuttle Feeder

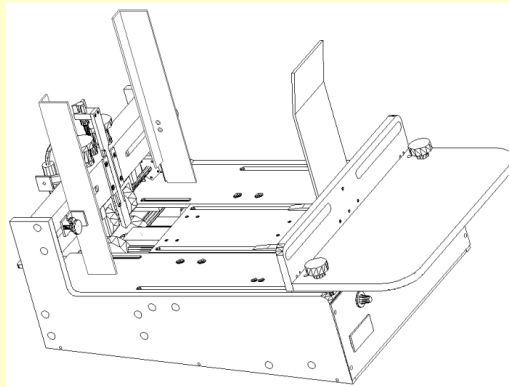

a shuttle type feeder for portable feeding of cards, self-mailers, magazines, etc.

Specifications

Machine

Dimensions: 30" L x 17" W x 18" H

Weight: 75 Pounds

Vacuum Shuttle & Pusher Blocks

Electrical

Power Requirements: 115 VAC, 60 Hz, 1 Ph, 3A

Shuttle Drive: 1/10 HP, DC Drive

Optional Vacuum Pump: 1/3 HP

Product

Minimum Size: 3" x 5" x 20#

Maximum Size: 11.0" x 15.0" x 0.375"

Throughput: 30,000 pieces per hour (product dependent)