



TJM Innovations - Magnacraft

5519 W. Woolworth Ave.

Milwaukee, WI 53218

Phone: (414) 206-2944

E-Mail: [orders@magnacraft.net](mailto:orders@magnacraft.net)

Website: [magnacraft.net](http://magnacraft.net)

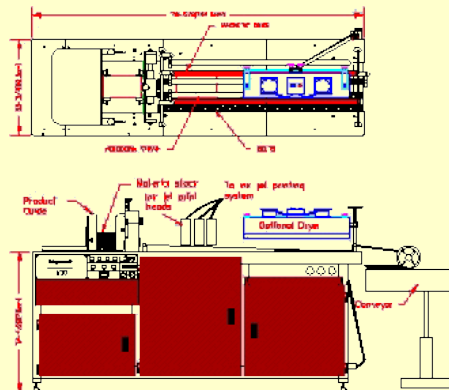

## 530-6' InkJet Base

### Specifications

#### Machine

Dimensions: 77" L x 30" W x 48" H

Weight: 708 Pounds

Dual Motor with Dual Controls

Dual Vacuum: Vacuum Shuttle & Vacuum Belt

#### Electrical

Power Requirements: 230 VAC, 60 Hz, 1 Ph, 30A

Shuttle Drive: 1/4 HP, DC Drive

Belt Drive: 1/6 HP, DC Drive

Vacuum Pump: 3/4 HP

Blower: 1/2 HP

Optional Dryer: 24" x 5", anti-glare quartz lamp, 2 blowers, 3000W, 230VAC, 13A

#### Product

Minimum Size: 3" x 5" x 20#

Maximum Size: 13.0" x 13.0" x 0.375"

Throughput: 30,000 pieces per hour (product dependent)

Product Spacing: Variable

#### Conveyor

Length 6 ft standard, 12 ft, or 18 ft optional

Configuration In-line or Right Angle

#### Application

Inkjet Base

Label Applicator Base